



Aluminum Propane Reel Series 40

Large Frame Reels Nordic™ Series 3900

Heavy Duty Large Frame Reels Nordic™ Series 3900

1½" Fluid Path for 1" through 1½" I.D. Hose

Rewind: Gear-drive rewind (new) or chain and sprocket drive powered by A.C. or D.C. electric motor, compressed air motor or hydraulic motor.

Inlet: 2" straight victaulic with 1½" female NPT straight swivel joint is standard. 2" victaulic 90° with 1½" NPT female available at extra cost.

Gooseneck: 1", 1¼" and 1½" female/male NPT outlet. Other sizes and/or threads can be furnished and must be specified.

ADD 12" to E dimension when crank is in rewind position.
The standard color for this series is red or gray.

NEW!
Gear drive option

Shown with optional bevel crank.

1/2" pitch chain now standard



Standard seals maximum temperature 174° F (79° C) and minimum temperature -20° F (-29° C). Extreme temperature seals maximum temperature 400° F (204° C) and minimum temperature -50° F (-45° C) and standard pressures to 600 PSI. Other temperatures or pressures can be furnished at extra cost, consult manufacturer.

Made in USA

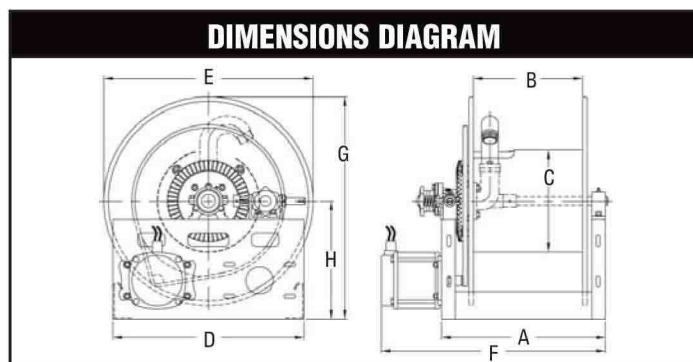

Note: Weights shown in chart are for crank rewind models.

Prefix	Type	LB / KG
EP	Electric	42 / 19
A	Air	26 / 12
H	Hyd	26 / 12

Add these amounts and model number prefix for power rewind models.

HOSE I.D.	in	1	1 1/4	1 3/8	1 1/2
	mm	25	32	35	38
HOSE O.D.	in	1.563	1.813	2.000	2.063
	mm	40	46	51	52

SPECIFICATIONS - HOSE CAPACITY AND REEL DIMENSIONS

KEY: CRK = hand crank; ELC = electric motor; HYD = hydraulic motor; AIR = air motor; BEVEL = bevel crank

MODEL	HOSE LENGTH (other std. lengths available)				EST. WEIGHT	A	B	C	D	E CRK	E ELC	E AIR	E HYD	F CRK	F ELC	F AIR	F HYD	G	H
	ft	m	ft	m															
3900-19-16	55	45	45	40	90 LB	in 22	16	11¼	21	21	21	22	21	26	29	26	28	22½	13
	17	14	14	12	41 KG	mm 559	406	286	533	533	533	559	533	660	737	660	711	572	330
3900-19-20	70	65	60	55	93 LB	in 26	20	11¼	21	21	21	22	21	30	33	30	32	22½	13
	21	20	18	17	42 KG	mm 660	508	286	533	533	533	559	533	762	838	762	813	572	330
3900-23-12	95	60	55	50	87 LB	in 18	12	11¼	21	23	23	24	23	22	25	22	24	24½	13
	29	18	17	15	39 KG	mm 457	305	286	533	584	584	610	584	559	635	559	610	622	330
3900-23-18	155	90	90	80	93 LB	in 24	18	11¼	21	23	23	24	23	28	31	28	30	24½	13
	47	27	27	24	42 KG	mm 610	457	286	533	584	584	610	584	711	787	711	762	622	330
3900-23-20	165	105	100	95	95 LB	in 26	20	11¼	21	23	23	24	23	30	33	30	32	24½	13
	50	32	30	29	42 KG	mm 660	508	286	533	584	584	610	584	762	838	762	813	622	330
3900-23-26	220	120	110	105	100 LB	in 32	26	11¼	21	23	23	24	23	36	39	36	38	24½	13
	67	37	34	32	45 KG	mm 813	660	286	533	584	584	610	584	914	991	914	965	622	330
3900-23-28	240	145	140	135	103 LB	in 34	28	11¼	21	23	23	24	23	38	41	38	40	24½	13
	73	44	43	41	47 KG	mm 864	711	286	533	584	584	610	584	965	1041	965	1016	622	330
3900-23-36	320	190	180	175	111 LB	in 42	36	11¼	21	23	23	24	23	46	49	46	48	24½	13
	98	58	55	53	50 KG	mm 1067	914	286	533	584	584	610	584	1168	1245	1168	1219	622	330
3900-25-12	95	85	55	50	89 LB	in 18	12	11¼	21	25	25	25	25	22	25	22	24	26½	14
	29	26	17	15	40 KG	mm 457	305	286	533	635	635	635	635	559	635	559	610	673	356
3900-25-20	165	155	100	95	97 LB	in 26	20	11¼	21	25	25	25	25	30	33	30	32	26½	14
	50	47	30	29	44 KG	mm 660	508	286	533	635	635	635	635	762	838	762	813	673	356
3900-31-12	210	155	115	105	92 LB	in 18	12	11¼	24	31	31	31	31	22	25	22	24	32½	17
	64	47	35	32	42 KG	mm 457	305	286	610	787	787	787	787	559	635	559	610	826	432
3900-31-16	305	205	155	150	96 LB	in 22	16	11¼	24	31	31	31	31	26	29	26	28	32½	17
	93	62	47	46	44 KG	mm 559	406	286	610	787	787	787	787	660	737	660	711	826	432
3900-31-20	365	275	200	190	100 LB	in 26	20	11¼	24	31	31	31	31	30	33	30	32	32½	17
	111	84	61	58	45 KG	mm 660	508	286	610	787	787	787	787	762	838	762	813	826	432

Refer to page 26 to build a complete model number.

HoseReelSales.com
813-241-4900



Wind Things Up With Reelcraft™