



Large Frame Reels Nordic™ Series 2400

Heavy Duty Large Frame Reels Nordic™ Series 2400

1/2", 3/4" or 1" Fluid Path for 1/2" through 1" I.D. Hose

Rewind: Gear-drive rewind (new) or chain and sprocket drive powered by A.C. or D.C. electric motor, compressed air motor or hydraulic motor.

Inlet: 1/2" up to 1" female/male NPT 90° swivel joint. Straight swivel joint may be specified at extra cost.

Gooseneck: 1/2" up to 1" female/male NPT. Other sizes and/or threads, including male NST and male garden hose thread, can be furnished when specified.

Product temperatures from -20° to +225°F and standard pressures to 3000 p.s.i. Reels to operate at other temperatures or pressures can be furnished at extra cost, consult manufacturer. The standard color for this series is red or gray. ADD 12" to E dimension when crank is in rewind position.

Made in USA

NEW!
Gear drive
option



**1/2" pitch chain
now standard**

Shown with optional
bevel crank.

DIMENSIONS DIAGRAM

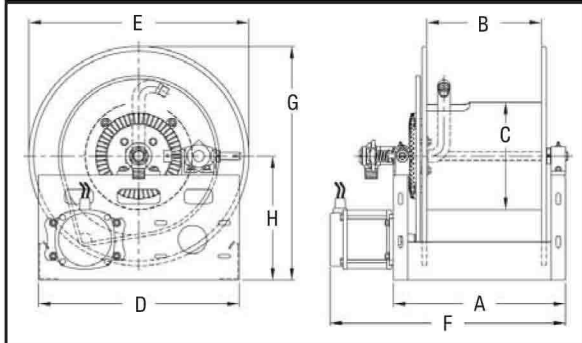

Fire Service / Booster Reels

The **aluminum Series 2400** reel for booster hose is corrosion-resistant and weighs up to 50% less than standard steel booster reels. Features include an aluminum spool and frame assembly, plated steel fluid path and plated sprocket and fasteners. **No painting or finishing is required.**



Nordic Series 2455

HOSE I.D.		in	1/2	3/4	1															
		mm	13	19	25															
HOSE O.D.		in	.875	1.281	1.563															
		mm	22	33	40															
MODEL	HOSE LENGTH (other std. lengths available)				EST. WEIGHT		A	B	C	D	E CRK	E ELC	E AIR	E HYD	F CRK	F ELC	F AIR	F HYD	G	H
2400-19-16	ft	200	100	50	70 LB	in	21	16	11.25	21	21	22	21	26	29	26	28	22.5	13	
	m	61	30	15	32 KG	mm	533	406	286	533	533	559	533	660	737	660	711	572	330	
2400-23-14	ft	315	150	100	74 LB	in	20	14	11.25	21	23	23	24	23	24	27	24	26	24.5	13
	m	96	46	30	34 KG	mm	508	356	286	533	584	584	610	584	610	686	610	660	622	330
2400-23-18	ft	485	240	150	78 LB	in	24	18	11.25	21	23	23	24	23	28	31	28	30	24.5	13
	m	148	73	46	35 KG	mm	610	457	286	533	584	584	610	584	711	787	711	762	622	330
2400-23-20	ft	535	260	165	80 LB	in	26	20	11.25	21	23	23	24	23	30	33	30	32	24.5	13
	m	163	79	50	36 KG	mm	660	508	286	533	584	584	610	584	762	838	762	813	622	330
2400-23-24	ft	625	300	200	84 LB	in	30	24	11.25	21	23	23	24	23	34	37	34	36	24.5	13
	m	191	91	61	38 KG	mm	762	610	286	533	584	584	610	584	864	940	864	914	622	330
2400-25-8	ft	235	125	60	72 LB	in	14	8	11.25	21	25	25	25	25	18	21	18	20	26.5	14
	m	72	38	18	33 KG	mm	356	203	286	533	635	635	635	635	457	533	457	508	673	356
2400-25-14	ft	450	225	110	74 LB	in	20	14	11.25	21	25	25	25	25	24	27	24	26	26.5	14
	m	137	69	34	34 KG	mm	508	356	286	533	635	635	635	635	610	686	610	660	673	356
2400-31-8	ft	435	185	125	74 LB	in	14	8	11.25	24	31	31	31	31	18	21	18	20	32.5	17
	m	133	56	38	34 KG	mm	356	203	286	610	787	787	787	787	457	533	457	508	826	432
2400-31-10	ft	540	235	165	76 LB	in	16	10	11.25	24	31	31	31	31	20	23	20	22	32.5	17
	m	165	72	50	34 KG	mm	406	254	286	610	787	787	787	787	508	584	508	559	826	432
2400-31-16	ft	900	400	300	80 LB	in	22	16	11.25	24	31	31	31	31	26	29	26	28	32.5	17
	m	274	122	91	36 KG	mm	559	406	286	610	787	787	787	787	660	737	660	711	826	432

SPECIFICATIONS - HOSE CAPACITY AND REEL DIMENSIONS

KEY: CRK = hand crank; ELC = electric motor; EXP = explosion-proof motor; AIR = air motor; BEVEL = bevel crank

Refer to page 26 to build a complete model number. Refer to chart on page 29 for weight adders.

HoseReelSales.com
813-241-4900



Wind Things Up With Reelcraft™